

FOM-E3, FOM-T3

E3/T3 Fiber Optic Modems

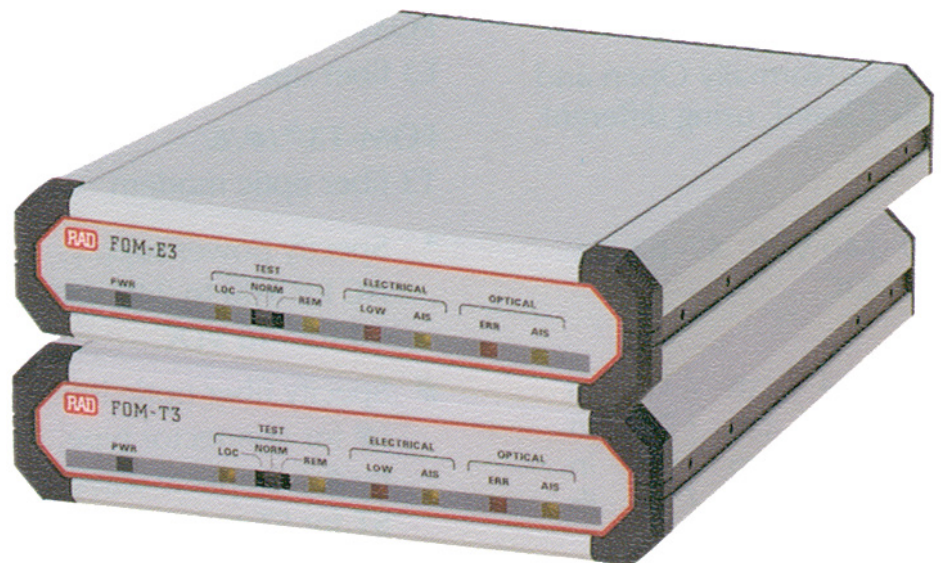

Convert E3/T3 electrical signals into optical signals, extending the E3/T3 service range up to 110 km (68.3 miles)

- High-speed fiber optic modems
- Transparent to E3/T3 signals
- Available with laser diode option for extended ranges
- Operate over single mode or multimode fibers
- Conform to all relevant ITU series standards, including V.54 diagnostics support



FOM-E3, FOM-T3

E3/T3 Fiber Optic Modems

The FOM-E3 and FOM-T3 fiber optic modems convert E3/T3 electrical signals into optical signals for transmission over fiber optic cable to extend the E3/T3 service range to up to 110 km (68.3 miles).

FOM-E3 and FOM-T3 support various optical interfaces:

- 850 nm VCSEL for multimode fiber
- 1310 nm laser for single-mode or multimode fiber
- 1310 nm and 1550 nm long-haul lasers for extended range over single-mode fiber
- WDM laser for transmission over a single fiber.

The modems are compatible with RAD's DXC, Optimux-34, Optimux-45, FOM-E3/ETH and FOM-T3/ETH devices.

FOM-E3 and FOM-T3 support activation of local and remote loopbacks in compliance with ITU V.54.

Front panel LEDs indicate system faults in the electrical and fiber optic circuits.

An alarm relay port transmits the following alarm conditions:

- Minor alarm – AIS received at the electrical or fiber optic interface
- Major alarm – low level of E3/T3 electrical input or high bit error rate at the fiber optic interface.

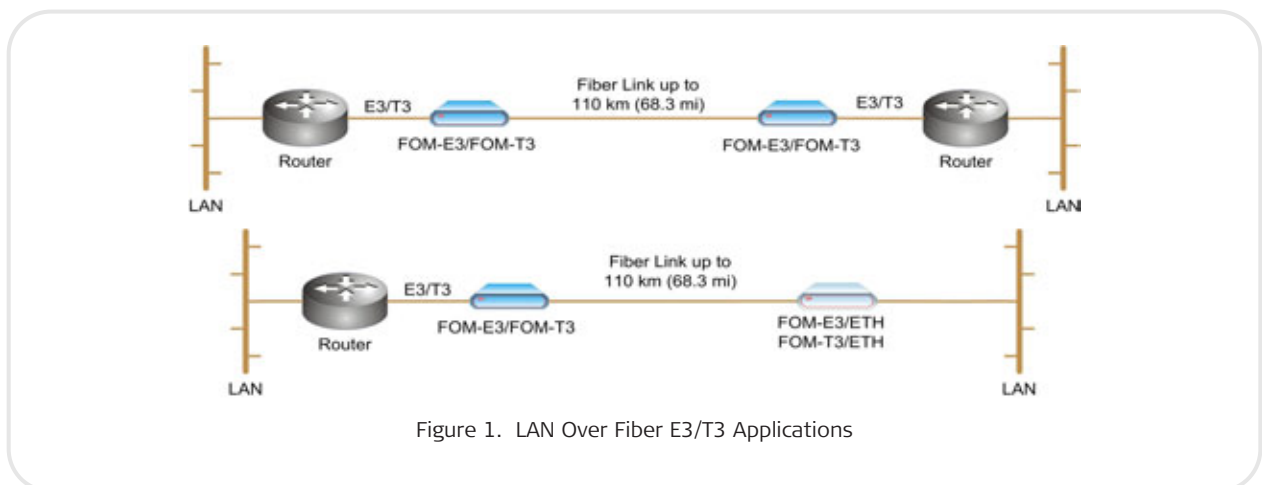

Figure 1. LAN Over Fiber E3/T3 Applications

Specifications

E3/T3 ELECTRICAL INTERFACE

Transmission Rate

E3: 34.368 Mbps
T3: 44.736 Mbps

Impedance

75Ω, unbalanced

Zero Suppression

E3: HDB3
T3: B3ZS

Connectors

Two BNC

FIBER OPTIC INTERFACE

Interface Characteristics

See *Table 1*

Connectors

ST, SC, SC-APC or FC

GENERAL

Diagnostics

Comply with ITU V.54; local and remote loopbacks activated via slide switch

Alarm Relay Port

Dry contact via 9-pin, D-type, female connector. Operates as normally open and normally closed, using different pins

Indicators

PWR (green): Power status
TEST LOC (yellow): Local loopback is active
TEST REM (yellow): Remote loopback is active
OPTICAL AIS (yellow): FO AIS status
OPTICAL ERR (red): FO bit error status
ELECTRICAL LOW (red): Electrical input status
ELECTRICAL AIS (yellow): Electrical AIS status

Physical

Height: 4.4 cm (1.7 in)
Width: 19.4 cm (7.6 in)
Depth: 24.3 cm (9.6 in)
Weight: 1.4 kg (3.0 lb)

Power

AC: 100–240 VAC, 47–63 Hz
DC: –48 VDC, 6.5W

Environment

Temperature: 0°–45°C (32°–113°F)
Humidity: Up to 90%, non-condensing

Table 1. Fiber Optic Interface Characteristics

Wavelength [nm]	Fiber Type [μm]	Transmitter Type	Power [dBm]	Receiver Sensitivity* [dBm]	Typical Max. Range**	
					[km]	[miles]
850	62.5/125 multimode	VCSEL	-15	-31	4.5	2.8
1310	62.5/125 multimode	Laser	-9	-31	5.5	3.4
1310	9/125 single mode	Laser	-12	-31	38	23.6
1310	9/125 single mode	Laser (long haul)	-2	-34	70	43.4
1550	9/125 single mode	Laser	-12	-31	68	42.2
1550	9/125 single mode	Laser (long haul)	-1	-34	110	68.3
1310/1550	9/125 single mode	Laser (WDM), SF1, SF2	-12	-30	40	24.9
1310	9/125 single mode	Laser (WDM), SF3	-12	-27	24	14.9

* Receiver sensitivity is calculated for BER = 10E⁻⁹.
** Range is calculated according to the following typical attenuation rates: 3.5 dB/km for 850 nm multimode, 0.5 dB/km for 1300 nm single mode, 0.25 dB/km for 1550 nm single mode. The max. range assumes a margin of 3 dB.

FOM-E3, FOM-T3

E3/T3 Fiber Optic Modems

Ordering

FOM-E3/~ab

FOM-T3/~ab

Legend

~ Power supply type:
AC 100 to 240 VAC
48 -20 to -72 VDC

a Connector type:
ST ST connector
SC SC connector
FC FC connector
SC-APC SC-APC connector

Note: SC-APC connector can only be ordered with SF3 transmitter

b Optical wavelength and transmitter:
85 850 nm, multimode, VCSEL
13MM 1310 nm, multimode, laser
13L 1310 nm, single mode, laser
15L 1550 nm, single mode, laser
13LH 1310 nm, single mode, long-haul laser
15LH 1550 nm, single mode, long-haul laser
SF1 Tx 1310 nm, Rx 1550 nm, WDM laser
SF2 Tx 1550 nm, Rx 1310 nm, WDM laser
SF3 Tx/Rx 1310 nm, WDM laser

Note: SF1 and SF2 transmitters can only be ordered with SC connector and SF3 transmitter can only be ordered with SC-APC connector

SUPPLIED ACCESSORIES

AC power cord
 DC connection kit (when DC power supply is ordered)

OPTIONAL ACCESSORIES

RM-9
 Hardware kit for mounting one or two FOM-E3 or FOM-T3 units in a 19-inch rack

Table 2. Fiber Optic Modem Comparison Chart

Feature	FOM-E1/T1	FOMi-E1/T1	FOM-20	FOM-40	FOMi-40	FOM-E3 FOM-T3	FOMi-E3 FOMi-T3	FOM-E3 ETH FOM-T3 ETH
Data rates [kbps]	E1/T1	E1/T1	19.2-256	56-2048	56-2048	E3 T3	E3 T3	E3 T3
DTE interfaces	G.703	G.703	Serial, Ethernet	Serial, Ethernet	Serial, Ethernet, E1/T1	G.703	G.703, HSSI	10/100BaseT VLAN bridge
SNMP management	-	✓	-	-	✓	-	✓	-
Card version for rack	ASM-MN-214	LRS-24	ASM-MN-214	ASM-MN-214	LRS-24	-	LRS-24	-

International Headquarters
 24 Raoul Wallenberg Street
 Tel Aviv 69719, Israel
 Tel. 972-3-6458181
 Fax 972-3-6498250, 6474436
 E-mail market@rad.com

North America Headquarters
 900 Corporate Drive
 Mahwah, NJ 07430, USA
 Tel. 201-5291100
 Toll free 1-800-4447234
 Fax 201-5295777
 E-mail market@radusa.com

www.rad.com



data communications
 The Access Company

282-100-07/08 Specifications are subject to change without prior notice. © 1988-2008 RAD Data Communications Ltd. The RAD name, logo, logo type, and the terms EtherAccess, TDMoIP and TDMoIP Driven, and the product names Optimux and Ibrnux, are registered trademarks of RAD Data Communications Ltd. All other trademarks are the property of their respective holders.